

Lysora L7Lite Access Point

Installation Guide

Copyright

Copyright © 2026 Lysora Technology Inc.

All rights are reserved in this document and this statement.

Without the prior written consent of Lysora Technology Inc., any organization or individual shall not reproduce, extract, back up, modify, or propagate the content of this document in any manner or in any form, or translate it into other languages or use some or all parts of the document for commercial purposes.

The  logo is the trademark of Lysora Technology Inc.

All other trademarks or registered trademarks mentioned in this document are owned by their respective owners.

Disclaimer

The products, services, or features you purchase are subject to commercial contracts and terms. Availability may vary by jurisdiction or contract, and some or all of the products, services, or features described in this document may not be available for you to purchase or use. **Except as expressly provided in a written agreement between you and Lysora Technology Inc., all representations and warranties, regarding the content of this document, to the maximum extent permitted by applicable law — including implied warranties of merchantability, fitness for a particular purpose, and non-infringement—are hereby disclaimed.**

The names, links, descriptions, screenshots, and any other information regarding third-party software mentioned in this document are provided for informational purposes only. **Lysora Technology Inc. does not endorse, recommend, guarantee, or assume liability for such third-party software's functionality, security, legality, accuracy, or fitness.** You are solely responsible for: (a) evaluating and selecting any third-party software based on your specific business requirements; (b) ensuring you have obtained all necessary licenses and authorizations for its use; and (c) assuming all risks associated with its use. **Lysora Technology Inc. shall have no liability for any claims or damages arising from your use of or reliance upon any third-party software.**

Lysora Technology Inc. reserves the right, at its sole discretion and without prior notice, to modify the content of this document at any time. These modifications may occur due to product updates, corrections, regulatory changes, or other reasons. **Lysora Technology Inc. undertakes no obligation to update or notify users of changes to this document.**

This document is provided "AS IS" and for general informational and guidance purposes only. While Lysora Technology Inc. strives to ensure the accuracy and reliability of the content at the time of publication, **it makes no warranty, express or implied, that the content is error-free, complete, or current.** All information contained herein is provided without any warranty of merchantability, fitness for a particular purpose, or non-infringement. **You assume all risk for the use or application of this information.** For regulatory compliance queries (e.g., FCC/CPSC standards), please contact our support channel.

Preface

Intended Audience

This document is intended for:

- Network engineers
- Technical support and servicing engineers
- Network administrators

Technical Support

- Official website: <https://help.lysoratech.com>
- Technical support email: support@lysoratech.com

Conventions

1. Symbols

The symbols that may be found in this document are described as follows:

Danger

An alert that calls attention to critical guidelines which, if not understood or followed, can result in personal injury.

Warning

An alert that calls attention to important information which, if not understood or followed, can result in data loss or equipment damage.

Caution

An alert that calls attention to essential information which, if not understood or followed, can result in functional failure or performance degradation.

Note

An alert that indicates additional or supplementary information.

 **Specification**

An alert that indicates a description of product or version support.

2. Notes

This document provides installation steps, troubleshooting, technical specifications, and usage guidelines about cables and connectors. It is intended for users who want to understand the above and have extensive experience in network deployment and management, and assume that users are familiar with related terms and concepts.

Contents

Preface.....	I
1 Product Overview.....	1
1.1 About the L7Lite.....	1
1.2 Product Appearance.....	1
1.2.1 Rear Panel.....	2
1.2.2 LED.....	3
1.3 Technical Specifications.....	5
1.4 Power Supply.....	10
1.5 Cooling.....	10
2 Preparing for Installation.....	11
2.1 Package Contents.....	11
2.2 Safety Guidelines.....	11
2.2.1 General Precautions.....	12
2.2.2 Chassis-Lifting Guidelines.....	12
2.2.3 Electricity Safety.....	12
2.3 Site Requirements.....	13
2.3.1 Floor Loading.....	13
2.3.2 Airflow.....	13
2.3.3 Temperature and Humidity.....	13
2.3.4 Cleanliness.....	14
2.3.5 Grounding.....	15
2.3.6 Preventing Electromagnetic Interference.....	15
2.4 Tools.....	15

3	Installing the AP	17
3.1	Before You Begin	17
3.2	Precautions	17
3.3	Installing the Equipment	18
3.3.1	Mounting the AP on a Ceiling or Wall	18
3.3.2	Mounting the AP in an 86 mm Junction Box	23
3.4	Removing the Equipment	25
3.5	Connecting Cables	26
3.6	Bundling up Cables	26
3.7	Checklist After Installation	27
4	Commissioning.....	28
4.1	Setting Up the Configuration Environment.....	28
4.2	Power-on	28
4.2.1	Checklist Before Power-on	28
4.2.2	Checklist After Power-on	28
4.3	Troubleshooting Power Supply Failures	28
4.4	Login to Web.....	28
5	Monitoring and Maintenance	30
5.1	Monitoring	30
5.2	Maintenance	30
6	Common Troubleshooting	31
6.1	General Troubleshooting Flowchart.....	31
6.2	Common Faults.....	31
7	Appendix.....	33

7.1 Connectors and Media	33
7.1.1 10/100/1000/2500BASE-T Ports.....	33
7.2 Cabling Recommendations	35
7.2.1 Requirement for the Minimum Bend Radius of Cables	35
7.2.2 Precautions for Cable Bundling.....	35

1 Product Overview

1.1 About the L7Lite

The L7Lite (HVIN: L2536) is a Wi-Fi 7 dual-band, ceiling-mounted wireless access point (AP) launched by Lysora, designed for indoor environments such as offices, hotels, and schools. It supports IEEE 802.3af/at-compliant Power over Ethernet (PoE) and a 12 V/1.5 A local power supply, allowing you to choose the most suitable power supply mode based on your needs. In compliance with IEEE 802.11a/b/g/n/ac/ax/be standards, the L7Lite operates on both the 2.4 GHz and 5 GHz frequency bands. It delivers ultra-fast speeds of up to 3570 Mbps, with 688 Mbps on the 2.4 GHz band and 2882 Mbps on the 5 GHz band, fulfilling requirements for high-speed wireless connectivity. This AP provides one 2.5 Gbps Ethernet port to fully utilize high-speed wireless performance. With self-organizing networking technology, the L7Lite ensures comprehensive indoor Wi-Fi coverage and meets diverse networking requirements for various services.

1.2 Product Appearance

Figure 1-1 L7Lite Appearance



1.2.1 Rear Panel

Figure 1-2 Rear Panel

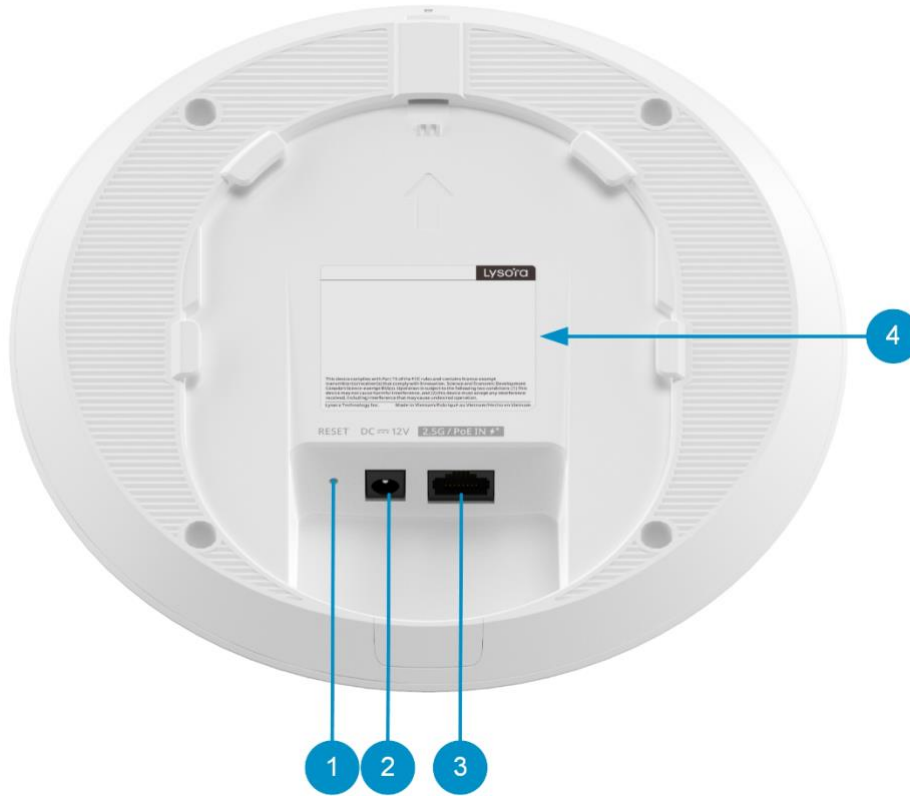

Note

⚡ indicates PoE+ port, which is compliant with IEEE 802.3af and IEEE 802.3at.

Table 1-1 Components on the Rear Panel

No.	Silkscreen	Component	Description
1	RESET	Reset button	Press and hold it for less than 2s to restart the AP.
			Press and hold it for more than 5s to restore the AP to factory settings.

No.	Silkscreen	Component	Description
2	DC=12V	DC power adapter port	Connects to a DC power adapter for power supply. The DC power voltage is 12 V and the current is 1.5 A.
3	2.5G/PoE IN	Ethernet port	1 x 10/100/1000/2500BASE-T Ethernet port that supports PoE input.
4	-	Nameplate	The nameplate is located on the rear panel of the AP, and provides the device name, model, default IP address, and other information.

1.2.2 LED

Figure 1-3 LED



Table 1-2 LEDs

No.	Silkscreen	Component	Status	Description
1	-	System status LED	Solid blue	The AP is operating normally without any alarms.
			Off	The AP is not receiving power.
			Fast blinking blue (eight blinks per second)	The AP is starting up.
			Slow blinking blue (one blink per 2 seconds)	The AP is not connected to the Internet.
			Blinking blue twice	<p>Possible cases are as follows:</p> <ul style="list-style-type: none"> ● The AP is being reset. ● The AP is being upgraded. ● The AP is recovering. <p>Caution: Do not power off the AP when its LED is in this state.</p>
			Blinking blue (three quick flashes followed by one slow flash)	Other faults have occurred.

1.3 Technical Specifications

Table 1-3 Technical Specifications

Parameter Type	Parameter Name	Description
Wi-Fi Radio	Radio design	Dual-radio 4 spatial streams <ul style="list-style-type: none"> ● 2.4 GHz: 2 x 2, MU-MIMO ● 5 GHz: 2 x 2, MU-MIMO
	5 GHz Wi-Fi	Wi-Fi 4 (IEEE 802.11a/n) Wi-Fi 5 (IEEE 802.11ac) Wi-Fi 6 (IEEE 802.11ax) Wi-Fi 7 (IEEE 802.11be)
	2.4 GHz Wi-Fi	Wi-Fi 4 (IEEE 802.11b/g/n) Wi-Fi 6 (IEEE 802.11ax) Wi-Fi 7 (IEEE 802.11be)
	Operating band	IEEE 802.11b/g/n/ax/be, 2.400 GHz to 2.4835 GHz IEEE 802.11a/n/ac/ax/be, 5.150 GHz to 5.350 GHz, 5.470 GHz to 5.725 GHz, 5.725 GHz to 5.850 GHz Note: Available bands vary with countries and regions. To use the preceding frequency bands, ensure that your country or region supports these frequency bands.
	Wireless data rate	2.4 GHz: 688 Mbps 5 GHz: 2882 Mbps Maximum wireless data rate: 3570 Mbps
	Modulation	OFDM: BPSK @ 6/9 Mbps, QPSK @ 12/18 Mbps, 16-QAM @ 24 Mbps, and 64-QAM @ 48/54 Mbps

Parameter Type	Parameter Name	Description
		<p>DSSS: DBPSK @ 1 Mbps, DQPSK @ 2 Mbps, and CCK @ 5.5/11 Mbps</p> <p>MIMO-OFDM: BPSK, QPSK, 16-QAM, 64-QAM, 256-QAM, 1024-QAM, and 4096-QAM</p> <p>OFDMA</p>
	Receive sensitivity	<p>11b: -91 dBm (1 Mbps), -88 dBm (5.5 Mbps), -85 dBm (11 Mbps)</p> <p>11a/g: -89 dBm (6 Mbps), -80 dBm (24 Mbps), -76 dBm (36 Mbps), -71 dBm (54 Mbps)</p> <p>11n: -83 dBm (MCS0), -65 dBm (MCS7), -83 dBm (MCS8), -65 dBm (MCS15)</p> <p>11ac: 20 MHz: -83 dBm (MCS0), -57 dBm (MCS9)</p> <p>11ac: 40 MHz: -79 dBm (MCS0), -57 dBm (MCS9)</p> <p>11ac: 80 MHz: -76 dBm (MCS0), -51 dBm (MCS9)</p> <p>11ac: 160 MHz: -76 dBm (MCS0), -50 dBm (MCS9)</p> <p>11ax: 20 MHz: -85 dBm (MCS0), -58 dBm (MCS11)</p> <p>11ax: 40 MHz: -82 dBm (MCS0), -54 dBm (MCS11)</p> <p>11ax: 80 MHz: -79 dBm (MCS0), -52 dBm (MCS11)</p> <p>11ax: 160 MHz: -76 dBm (MCS0), -49 dBm (MCS11)</p> <p>11be: 20 MHz: -85 dBm (MCS0), -52 dBm (MCS13)</p> <p>11be: 40 MHz: -82 dBm (MCS0), -49 dBm (MCS13)</p> <p>11be: 80 MHz: -82 dBm (MCS0), -46 dBm (MCS13)</p> <p>11be: 160 MHz: -79 dBm (MCS0), -44 dBm (MCS13)</p>
	Maximum transmit power	<p>Frequency bands and maximum Effective Isotropic Radiated Power (EIRP):</p> <p>Note: Country specific restrictions apply.</p>

Parameter Type	Parameter Name	Description
		<ul style="list-style-type: none"> ● European Union & United Kingdom <ul style="list-style-type: none"> ○ 2400–2483.5 MHz, EIRP ≤ 20 dBm ○ 5150–5350 MHz, EIRP ≤ 23 dBm ○ 5470–5725 MHz, EIRP ≤ 30 dBm ● Myanmar: <ul style="list-style-type: none"> ○ 2400–2483.5 MHz, EIRP ≤ 23 dBm ○ 5725–5825 MHz, EIRP ≤ 30 dBm ● Thailand: <ul style="list-style-type: none"> ○ 2400–2483.5 MHz, EIRP ≤ 20 dBm ○ 5150–5350 MHz, EIRP ≤ 23 dBm ○ 5470–5725 MHz, EIRP ≤ 30 dBm ○ 5725–5825 MHz, EIRP ≤ 30 dBm ● Indonesia: <ul style="list-style-type: none"> ○ 2400–2483.5 MHz, EIRP ≤ 27 dBm ○ 5150–5350 MHz, EIRP ≤ 23 dBm ○ 5725–5825 MHz, EIRP ≤ 23 dBm ● Egypt: <ul style="list-style-type: none"> ○ 2400–2483.5 MHz, EIRP ≤ 20 dBm ○ 5150–5350 MHz, EIRP ≤ 23 dBm
	Power Step	1 dBm
Antenna	Antenna	2.4 GHz: 2 built-in omnidirectional antennas 5 GHz: 3 built-in omnidirectional antennas

Parameter Type	Parameter Name	Description
	Antenna gain (5 GHz)	4.44 dBi
	Antenna gain (2.4 GHz)	3.23 dBi
Dimensions and Weight	Product dimensions (diameter x height)	Ø195 mm x 41 mm (Ø7.68 in. x 1.61 in.) (excluding the mounting bracket)
	Weight	≤ 0.6 kg (1.32 lbs.) (without packaging materials)
	Shipping weight	≤ 1 kg (2.2 lbs.)
	Color	White
Port Specifications	Number of 10/100/1000/2500BASE-T ports	1
	Reset button	1
	LEDs	1 x system status LED
Power Supply and Consumption	Power Supply	<ul style="list-style-type: none"> ● DC power adapter ● PoE/PoE+ <p>Note: If both the DC power adapter and PoE/PoE+ are available for power supply, the DC power adapter is preferred.</p>
	Local power supply	Yes, one DC power connector (12 V, 1.5 A)

Parameter Type	Parameter Name	Description
	Dimensions of the DC connector	Outer diameter: 5.5 mm (0.22 in.) Inner diameter: 2.1 mm (0.08 in.) Depth: 10 mm (0.39 in.)
	PoE In standard	<ul style="list-style-type: none"> ● IEEE 802.3af (PoE) ● IEEE 802.3at (PoE+)
	Maximum power consumption	14 W
Environment and Reliability	Operating temperature	0°C to +40°C (32°F to +104°F)
	Storage temperature	-40°C to +70°C (-40°F to +158°F)
	Operating humidity	5% RH to 95% RH (non-condensing)
	Storage humidity	5%RH to 95% RH (non-condensing)
	Mounting options	Ceiling/Wall
	Surge protection	Ethernet port: ±2 kV for common mode
	MTBF	400,000 hours
Certification and Regulatory Compliance	RoHS	Yes
	Certification	FCC, IC, cTUVus

! Warning

- In a domestic environment, this product may cause radio interference, in which case the user may be required to take adequate measures.
 - This device does not support the 6G frequency band (5925MHz-7125MHz).
-

1.4 Power Supply

The L7Lite supports DC and PoE power supply.

- When the AP is powered by a DC power adapter, the power adapter should have a voltage of 12 V and a current of 1.5 A. Dimensions of the DC power connector (outer diameter x inner diameter x depth): 5.5 mm x 2.1 mm x 10 mm (0.22 in. x 0.08 in. x 0.39 in.).
- When the AP is powered by standard PoE, connect one end of the Ethernet cable to the LAN/2.5G/PoE port on the AP, and the other end to a PoE-capable switch or any other PoE power source equipment (PSE). For optimal performance, you are advised to use an IEEE 802.3af/at-compliant PoE power source.

! Caution

The DC input power of the DC power adapter must be greater than the actual power consumption of the AP.

1.5 Cooling

The AP adopts the fanless design. Therefore, when installing the AP, ensure that there is sufficient clearance around the AP for heat dissipation.

2 Preparing for Installation

2.1 Package Contents

Table 2-1 Package Contents

No.	Item	Quantity
1	L7Lite access point	1
2	Mounting bracket	1
3	Cross pan head screws (ST4.2 x 20 mm)	4
4	Plastic expansion anchors ($\varphi 9 \times 25.4$ mm)	4
5	User Manual	1
6	Key to security lock	1
7	Alignment sticker	1
8	Warranty Card	1

Note

The package contents are subject to the purchase contract, and actual delivery may vary. Please check the items carefully against the package contents or purchase contract. If you have any questions, please contact the distributor.

2.2 Safety Guidelines

Note

- To avoid personal injury or equipment damage, review the safety guidelines in this chapter before you begin the installation.
 - The following safety guidelines may not include all the potentially hazardous situations.
-

2.2.1 General Precautions

- Do not expose the equipment to high temperatures, dust, or harmful gases. Do not install the equipment in flammable or explosive environments. Keep the equipment away from sources of electromagnetic interference (EMI), such as large radar stations, radio stations, and substations. Do not subject the equipment to unstable voltage, vibration, or excessive noise.
- The installation site should be dry. Do not install the equipment in a place near the sea. Keep the equipment at least 500 m (1640.42 ft.) away from the ocean and do not face it towards the sea breeze.
- The installation site should be free from water flooding, seepage, dripping, or condensation. The installation site should be selected according to network planning and communications equipment features, and considerations such as climate, hydrology, geology, earthquake, electrical power, and transportation.
- Ensure that the equipment and power distribution system are properly grounded.
- The product and power supply equipment can only be installed and used in the same building.

Caution

Follow the procedures in the user manual to install and remove the equipment.

2.2.2 Chassis-Lifting Guidelines

- Avoid moving the equipment frequently.
- Cut off all power supplies and disconnect all cables before lifting or moving the equipment.

2.2.3 Electricity Safety

Warning

- Any deviation from standard or improper electrical operations can result in accidents such as fires or electric shocks, potentially causing severe or even fatal harm to both individuals and equipment.
 - Direct or indirect touch through a wet object on high-voltage and mains supply can bring a fatal danger.
-

- Always observe the local regulations and standards. Only qualified personnel should

be allowed to operate the equipment.

- Check whether there are potential risks in the working area. For example, check whether the grounding is reliable, and whether the ground is wet.
- Locate the emergency power-off switch in the room before installation. In the case of an accident, cut off the power supply immediately.
- Check the equipment carefully before shutting down the power supply.
- Keep the equipment far away from the grounding facility and lightning protection facility of the power equipment.
- Keep the equipment away from radio stations, radar stations, high-frequency and high-current equipment, microwave ovens, and other high-power wireless equipment.

2.3 Site Requirements

Install the equipment indoors to ensure its normal operation and prolonged service life. The installation site must meet the following requirements.

2.3.1 Floor Loading

Evaluate the weight of the equipment and its accessories, and ensure that the installation site (such as a wall) can bear the weight.

2.3.2 Airflow

The equipment adopts natural cooling. Reserve a sufficient clearance around the equipment to ensure proper ventilation.

2.3.3 Temperature and Humidity

To ensure the normal operation and prolonged service life of the equipment, maintain appropriate temperature and humidity in the equipment room. Working in an environment with too high or too low temperature and humidity for a long period may damage the equipment.

- When exposed to high relative humidity, insulating materials may exhibit poor insulation capabilities, increasing the risk of electrical leakage. Sometimes, high humidity may cause changes in the mechanical properties and cause rusting of metal parts.
- When exposed to low relative humidity, the insulating strip may dry out and shrink, increasing the risk of static electricity generation.

- Too high temperatures can accelerate the aging of insulation materials, greatly reducing the reliability of the equipment and severely affecting its service life.

Table 2-2 **Temperature and Humidity Requirements**

Operating Temperature	Operating Humidity
0°C to 40°C (32°F to +104°F)	5% RH to 95% RH (non-condensing)

2.3.4 Cleanliness

Dust poses a major threat to the equipment. The indoor dust can cause electrostatic adhesion when falling on the equipment, causing poor contact of the metallic joint. Such electrostatic adhesion occurs more easily when the indoor relative humidity is low, not only affecting the service life of the equipment, but also causing communication failure easily. The following table lists the requirements for the dust content and diameter in the equipment room.

Table 2-3 **Dust and Particles**

Particle Diameter	Unit	Concentration
≥ 0.5 μm	Particles/m ³	≤ 1.4 × 10 ⁷
≥ 1 μm	Particles/m ³	≤ 7 × 10 ⁵
≥ 3 μm	Particles/m ³	≤ 2.4 × 10 ⁵
≥ 5 μm	Particles/m ³	≤ 1.3 × 10 ⁵

Apart from dust, the salt, acid, and sulfide in the air of the equipment room must meet strict requirements. These harmful substances will accelerate metal corrosion and component aging. The equipment room should be protected from harmful gases (such as sulfur dioxide, hydrogen sulfide, nitrogen dioxide, ammonia, and chlorine). The following table lists the limits of harmful gases in the equipment room.

Table 2-4 Hazardous Gases

Gas	Average (mg/m ³)	Maximum (mg/m ³)
Sulfur dioxide (SO ₂)	0.2	1.5
Hydrogen sulfide (H ₂ S)	0.006	0.03
Nitrogen dioxide (NO ₂)	0.04	0.15
Ammonia gas (NH ₃)	0.05	0.15
Chlorine gas (Cl ₂)	0.01	0.3

Note

The average value is measured over one week. The maximum value is the upper limit of the harmful gas measured in one week for up to 30 minutes every day.

2.3.5 Grounding

A proper grounding system is the basis for stable and reliable running and is indispensable for preventing lightning strikes and interference. Carefully check the grounding conditions at the installation site according to the grounding specifications, and complete grounding properly based on the actual situation.

2.3.6 Preventing Electromagnetic Interference

- Keep the AP away from grounding or lightning protection devices for power equipment.
- Keep the AP away from radio stations, radar stations, high-frequency high-current equipment, microwave ovens, and other high-power wireless equipment.

2.4 Tools

Table 2-5 Tools

Common Tools	Phillips screwdriver, cables, Ethernet cables, diagonal pliers, and cable ties
---------------------	--

Special Tools	ESD-preventive gloves, wire stripper, crimping pliers, RJ45 crimping pliers, wire cutter, and waterproof tape
Meters	Multimeter and bit error rate tester (BERT)

 Note

The equipment is delivered without a toolkit. Prepare the preceding tools by yourself.

3 Installing the AP

The AP is required to be fixed indoors.

Caution

Before installing the equipment, ensure that guidelines and requirements in Chapter 2 have been met.

3.1 Before You Begin

Carefully plan and arrange the installation position, networking mode, power supply, and cabling before installation. Confirm the following requirements before installation:

- The installation site should provide sufficient space for heat dissipation.
- The installation site meets the temperature and humidity requirements of the equipment.
- The power supply is available at the installation site, and its current meets the requirements.
- The power supply meets the requirements.
- The installation site meets the cabling requirements of the equipment.
- The installation site meets the site requirements of the equipment.
- The customized equipment meets the client-specific requirements.

3.2 Precautions

To avoid damage to the access point, observe the following safety precautions:

- Do not power on the equipment during installation.
- Place the equipment in a well-ventilated environment.
- Do not subject the equipment to high temperatures.
- Keep the equipment away from high-voltage power cables.
- Do not expose the equipment to a thunderstorm or strong electric field.
- Keep the access point clean and dust-free.
- Cut off the power supply before cleaning the equipment.

- Do not wipe the device with a damp cloth.
- Do not wash the device with liquid.
- Do not open the enclosure when the equipment is working.
- Secure the equipment properly.

3.3 Installing the Equipment

i Note

- For indoor environments, ceiling mounting is preferred because it offers a broader coverage area than wall mounting.
 - This installation guide is for reference only. The actual installation procedure may differ depending on the specific product.
-

3.3.1 Mounting the AP on a Ceiling or Wall

- (1) Drill holes in the ceiling or wall using the alignment sticker.

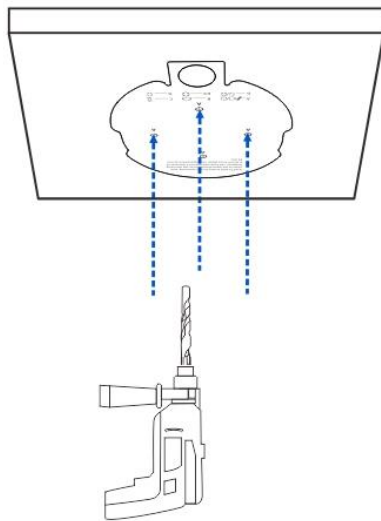

- (2) Secure the mounting bracket to the ceiling or wall using plastic expansion anchors ($\varphi 9 \times 25.4$ mm) and cross pan head screws (ST4.2 x 20 mm).

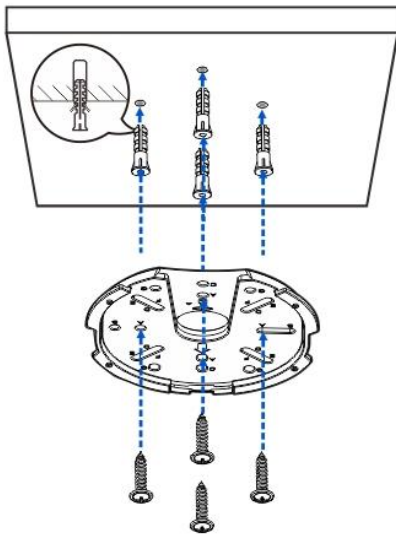

⚠ Caution

The plane deviation of the wall in the installation area should be within 2 mm (0.08 in.), and the recommended torque for installation is 4kgf.cm. In case of an uneven installation area, mount the AP on a protruding wall using screws.

- (3) Connect cables according to the actual topology. The following describes how to connect cables on the AP side.
- Ethernet cable: Connect one end of the Ethernet cable to the 2.5G/PoE IN port (supporting PoE input) on the rear of the AP.
 - DC power cord: When DC power supply is used, connect one end of the power cord to the 12 V DC power connector on the rear of the AP.

The cables can be routed either through concealed wiring or exposed wiring methods.

○ Concealed wiring:

- a. Route the cable through the ceiling or wall and connect it to the Ethernet port on the rear of the device.

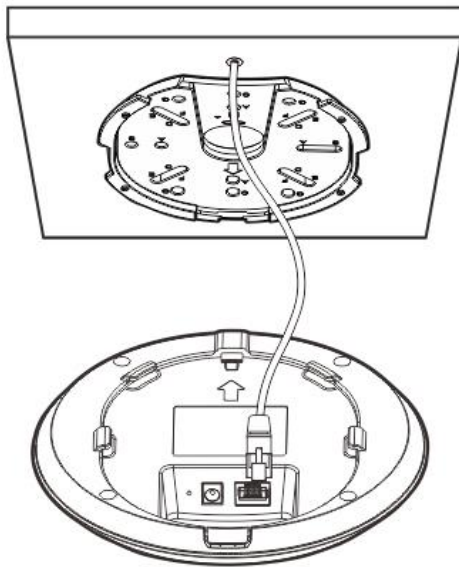

- b. Align the slots on the rear of the AP with the square feet on the mounting bracket, and slide the AP into the mounting bracket slowly to ensure that the AP is secured.

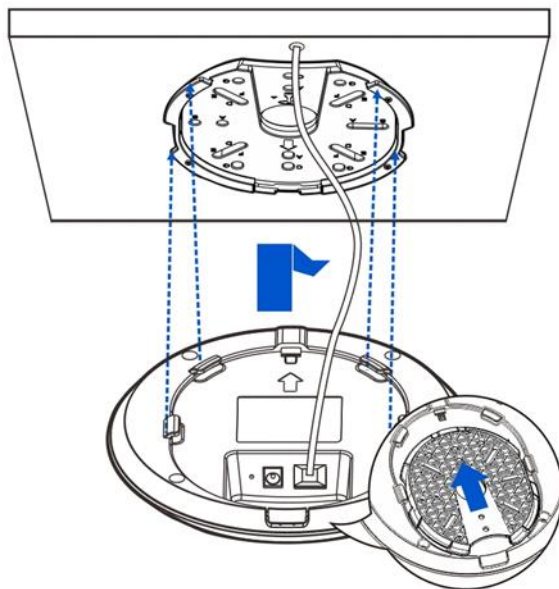

- c. The installation is complete.

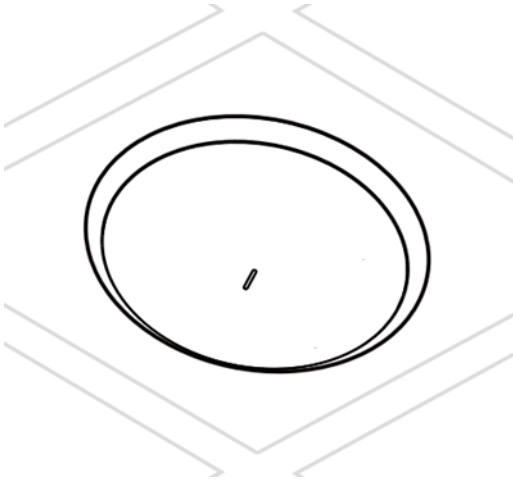

- o Exposed wiring:
 - a. Remove the knockout from the cable inlet opening and route the cable through it.

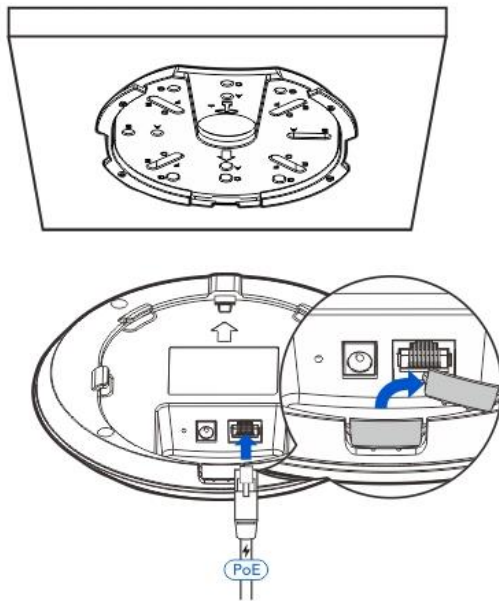

- b. Align the slots on the rear of the AP with the square feet on the mounting bracket, and slide the AP into the mounting bracket slowly to ensure that the AP is secured.

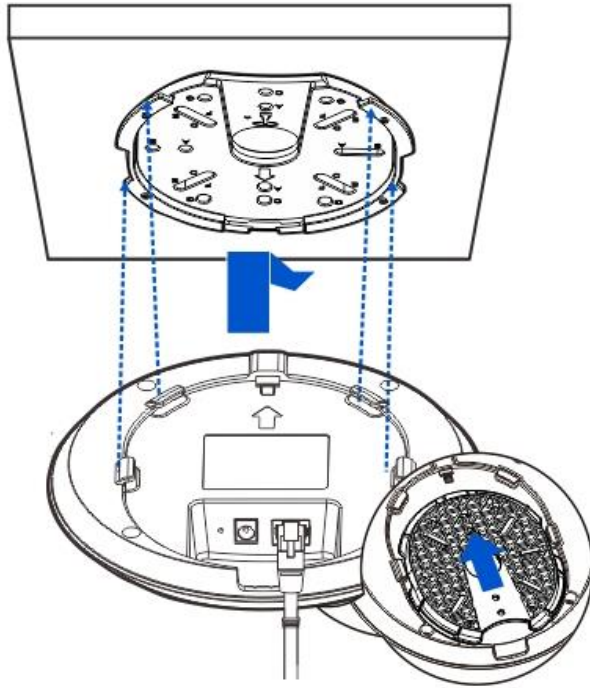

c. The installation is complete.

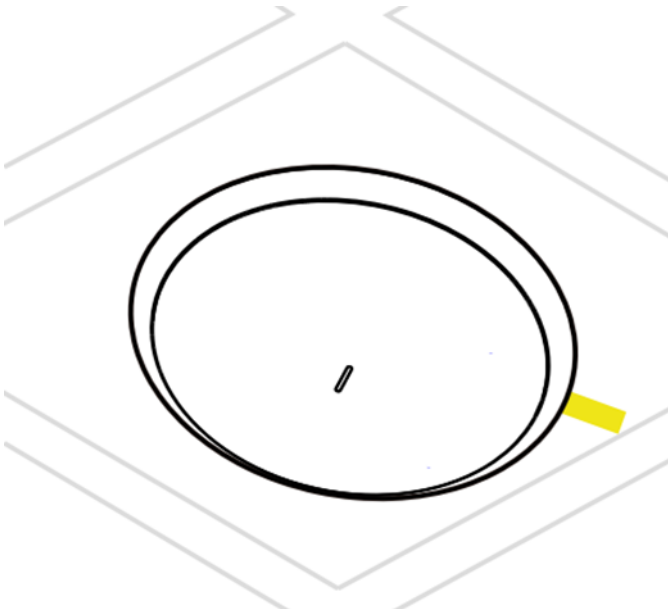

⚠ Caution

- Before securing the AP to the mounting bracket, connect the cables first.

- Align the slots on the rear of the AP and slide them into the square feet on the mounting bracket. Do not press the slots into the square feet by force.
- After the installation is complete, check whether the AP is secured.

3.3.2 Mounting the AP in an 86 mm Junction Box

- (1) Remove the cover of the 86 mm junction box.

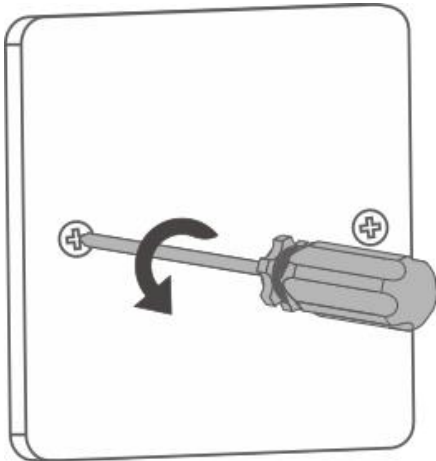

- (2) Align the mounting holes of the bracket with the screw holes in the 86 mm junction box. Then, secure the bracket to the junction box using cross pan head screws (ST4.2 x 20 mm).

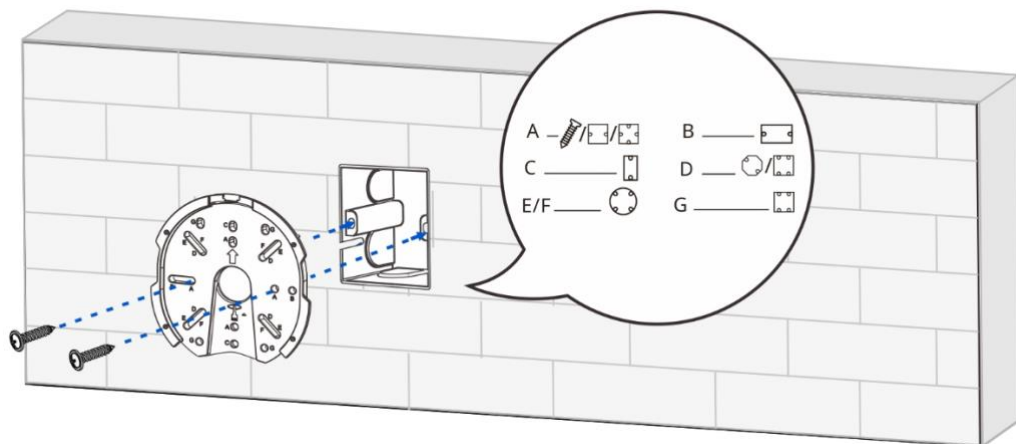

Note

Select a mounting bracket with different hole combinations based on junction box specifications.

(3) Connect cables according to the actual topology. The following describes how to connect cables on the AP side.

- Ethernet cable: Connect one end of the Ethernet cable to the 2.5G/PoE IN port (supporting PoE input) on the rear of the AP.
- DC power cord: When DC power supply is used, connect one end of the power cord to the 12 V DC power connector on the rear of the AP.

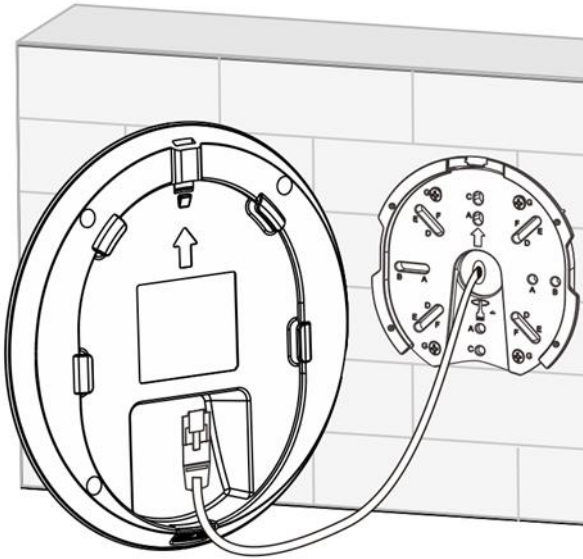

(4) Align the slots on the rear of the AP with the square feet on the mounting bracket, and slide the AP into the mounting bracket slowly to ensure that the AP is secured.

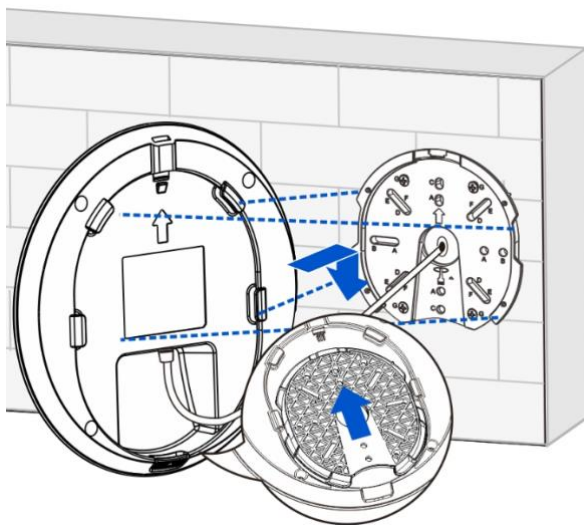

(5) The installation is complete.

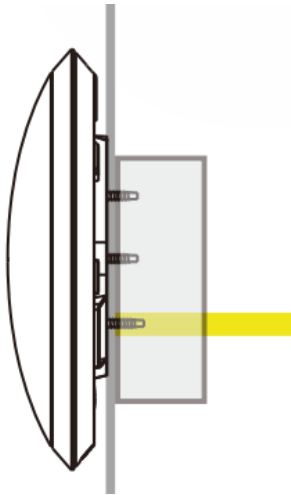

⚠ Caution

- Before securing the AP to the mounting bracket, connect the cables first.
 - Align the slots on the rear of the AP and slide them into the square feet on the mounting bracket. Do not press the slots into the square feet by force.
 - After the installation is complete, check whether the AP is secured.
-

3.4 Removing the Equipment

(1) Insert the key to security lock into the reserved slot.

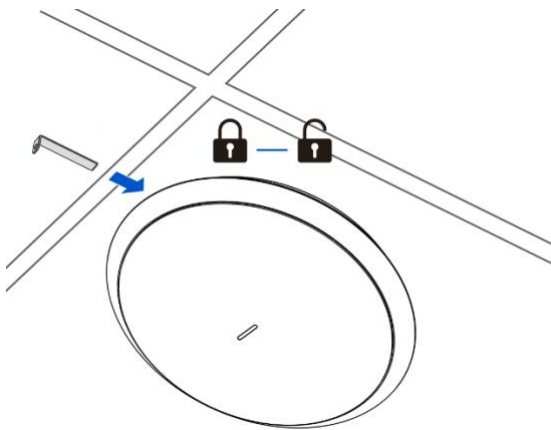

(2) Slide down the AP as indicated by the arrow.

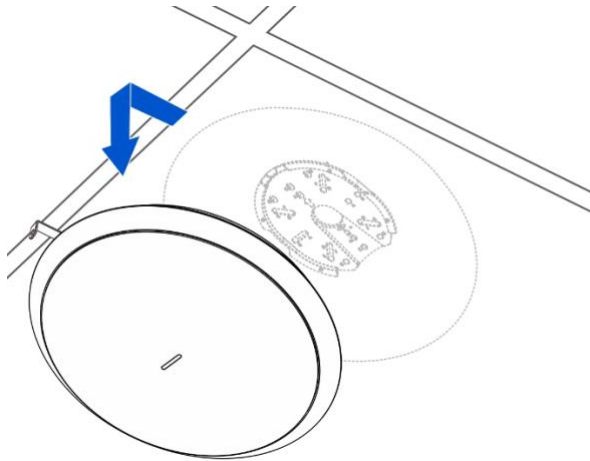

3.5 Connecting Cables

Connect twisted pairs with the Ethernet port on the AP. See [7.1 Connectors and Media](#) for supported wiring of twisted pairs.

⚠ Caution

- Avoid a small bend radius at the connector.
 - You are advised not to use Ethernet cables with protective caps for the L7Lite, as they complicate the assembly of the Ethernet cables.
-

3.6 Bundling up Cables

Precautions

- Bundle the cable in a visually pleasing way.
- Bend twisted pairs naturally or to a large radius close to the connector.
- Do not over-tighten the twisted pair bundle as it may reduce the cable life and performance.

Bundling Steps

- (1) Bundle the hanging part of the twisted pairs using cable ties and lead them to the LAN/PoE port of the AP by convenience.
- (2) Fasten the twisted pair cables to the cable trough of the mounting bracket.
- (3) Extend the twisted pair cables under the AP and route them in a straight line.

3.7 Checklist After Installation

- Checking the AP
 - Verify that the external power supply meets the requirement of the AP.
 - Verify that the AP is securely fastened.
- Checking the Cable Connection
 - Verify that the cable type matches the port type.
 - Verify that the cables are properly bundled.
- Checking the Power Supply
 - Verify that the power cord is properly connected and meets safety requirements.
 - Verify that the AP works properly when powered by the power supply.

4 Commissioning

4.1 Setting Up the Configuration Environment

After powering on the AP through a DC power adapter or a PSE, ensure that the power cord is properly connected and meets safety requirements.

4.2 Power-on

4.2.1 Checklist Before Power-on

- The power cord is properly connected.
- The power voltage meets the requirement.

4.2.2 Checklist After Power-on

- Verify the LED status.
- After the AP is powered on, check whether the SSID (@Lysora-mXXXX for multiple devices or @Lysora-sXXXX for a single device) can be searched by a mobile phone or other wireless devices.

4.3 Troubleshooting Power Supply Failures

You can determine whether there is a power system failure by checking the LED status on the front panel of the L7Lite. For the LED status description, see [Table 1-2 LEDs](#).

Perform the following checks in the case of any abnormality:

- Verify that the AP is properly powered.
- Verify that the Ethernet port is correctly connected.

Note

If the AP cannot be powered on after all the preceding items are verified, contact your local distributor or technical support.

4.4 Login to Web

Wired Connection

- (1) Connect a PC to an Ethernet port on the equipment through an Ethernet cable.

- (2) Power on the PC and configure the local connection attribute on the PC. Set the IP address of the PC to 10.100.111.XXX (1 to 252).
- (3) Open a browser on the PC and enter 10.100.111.254 to log in to the web interface. The default password is admin for the first login. For security purposes, change the default password after login.

5 Monitoring and Maintenance

5.1 Monitoring

When the L7Lite is operating, you can monitor the device running status by observing the LED.

5.2 Maintenance

If the hardware is faulty, please contact the local distributor.

6 Common Troubleshooting

6.1 General Troubleshooting Flowchart

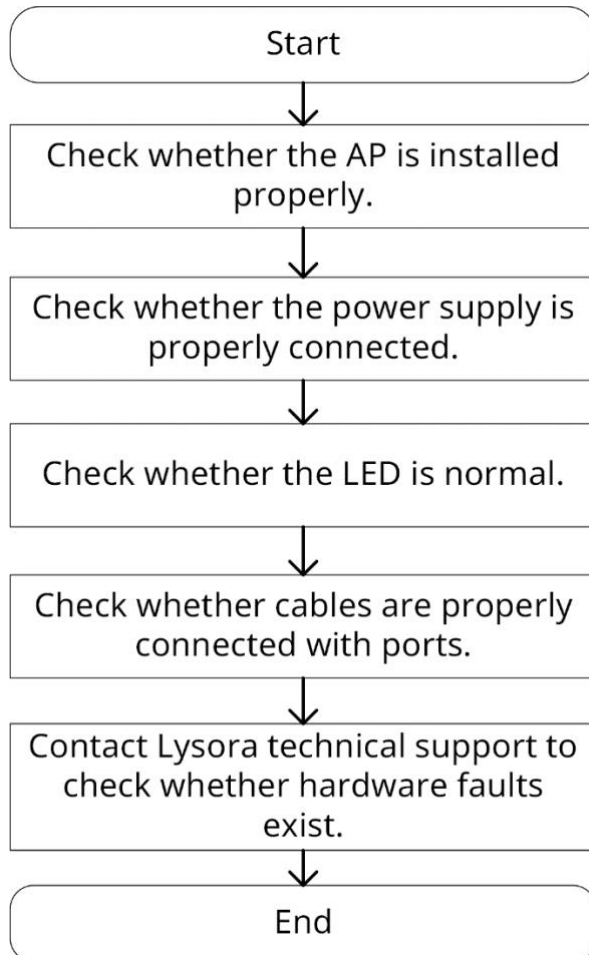

6.2 Common Faults

- Why is the LED off after the equipment is powered on?
 - If you use a PoE power supply, verify that the PSE is IEEE 802.3af/at-compliant, and then verify that the cable is connected properly.
 - If you use a power adapter, verify that the power adapter is connected with an active power outlet, and then verify that the power adapter works properly.
- Why does the Ethernet port fail to work after the Ethernet cable is connected to it?

Verify that the peer equipment is working properly. Then, verify that the Ethernet cable is capable of providing the required data rate and is properly connected.

- Why can't clients discover the AP?
 - Verify that the equipment is properly powered.
 - Verify that the Ethernet port is correctly connected.
 - Check whether the AP is correctly configured.
 - Move the client to adjust the distance between it and the AP.

7 Appendix

7.1 Connectors and Media

7.1.1 10/100/1000/2500BASE-T Ports

The 10/100/1000/2500BASE-T port supports auto-negotiation for 10Mbps, 100 Mbps, 1000 Mbps, and 2500 Mbps connections and also supports auto MDI/MDIX Crossover.

Compliant with IEEE 802.3bz, a 2500BASE-T port requires 100-ohm Category 6 (CAT6) or Category 5 Enhanced (CAT5e) unshielded twisted pair (UTP), or recommended shielded twisted pair (STP) cables with a maximum distance of 100 meters (328.08 feet). When a PoE power supply is used, CAT6 STP cables are recommended, and both the port and the cable should be properly shielded.

Compliant with IEEE 802.3ab, a 1000BASE-T port connects to a 100-ohm Category 5 (CAT5) or Category 5 Enhanced (CAT5e) Unshielded Twisted Pair (UTP), recommended Shielded Twisted Pair (STP), or higher-standard cable with a maximum distance of 100 meters (328.08 feet).

The 2500BASE-T or 1000BASE-T port requires that all four pairs of wires be connected for data transmission.

Figure 7-1 Connections of Four Twisted Pairs for a 1000/2500BASE-T Port

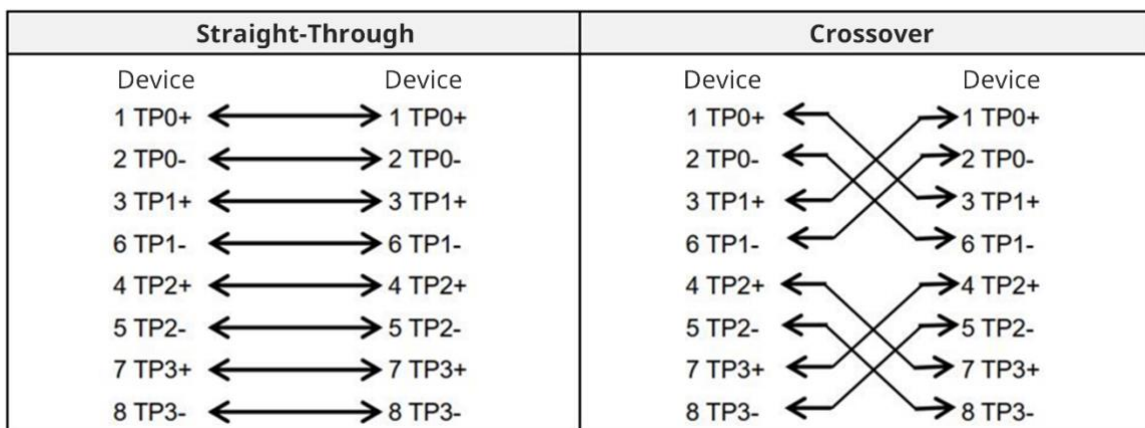

The 100BASE-TX or 10BASE-T port can also be connected by cables of the preceding specifications. Besides, the 10BASE-T port can be connected by 100-ohm Category 3, Category 4, and Category 5 cables with a maximum distance of 100 meters (328.08 ft.). The 100BASE-TX port can be connected by 100-ohm Category 5 cables with a maximum

distance of 100 meters (328.08 ft.). The following table shows pin assignments for 100BASE-TX or 10BASE-T ports.

Table 7-1 Pin Assignments for 100BASE-TX or 10BASE-T Ports

Pin	Socket	Plug
1	Input Receive Data+	Output Transmit Data+
2	Input Receive Data-	Output Transmit Data-
3	Output Transmit Data+	Input Receive Data+
6	Output Transmit Data-	Input Receive Data-
4, 5, 7, 8	Not Used	Not Used

The following table shows wiring of straight-through and crossover cables for the 100BASE-TX or 10BASE-T ports.

Figure 7-2 Twisted Pair Connections for 100BASE-TX or 10BASE-T Ports

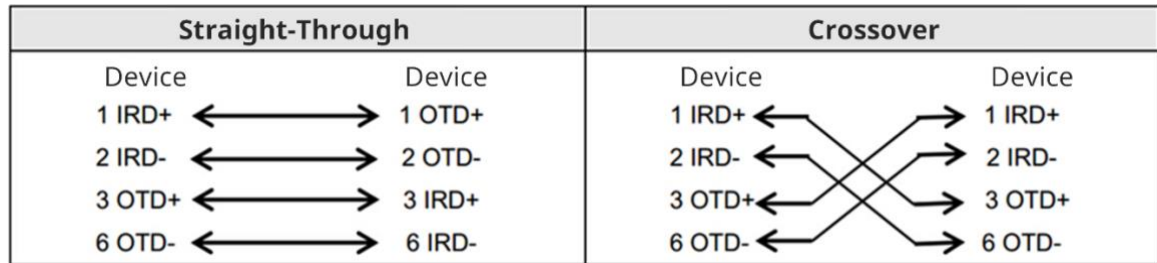

7.2 Cabling Recommendations

During installation, route cable bundles upward or downward along the sides of the cable management bracket depending on the actual situation in the equipment room. All adapted connectors should be placed at the bottom of the rack in an orderly manner instead of outside the rack that is easy to touch. Power cords are routed beside the rack. Top cabling or bottom cabling is adopted according to the actual situation in the equipment room, such as the positions of the DC power distribution box, AC socket, or lightning protection box.

7.2.1 Requirement for the Minimum Bend Radius of Cables

- The bend radius of a fixed power cord, Ethernet cable, and flat cable should be over five times greater than their respective external diameters. The bend radius of these cables that are often bent or plugged should be over seven times greater than their respective external diameters.
- The bend radius of a fixed common coaxial cable should be over seven times greater than its external diameter. The bend radius of these cables that are often bent or plugged should be over 10 times greater than their respective external diameters.
- The minimum bend radius of a high-speed cable, such as an SFP+ cable, should be over five times greater than its external diameter. The bend radius of these cables that are often bent or plugged should be over 10 times greater than their respective external diameters.

7.2.2 Precautions for Cable Bundling

- Before cables are bundled, mark labels and stick the labels to cables wherever appropriate.
- Cables should be neatly and properly bundled in the rack without twisting or bending, as shown in [Figure 7-3](#).

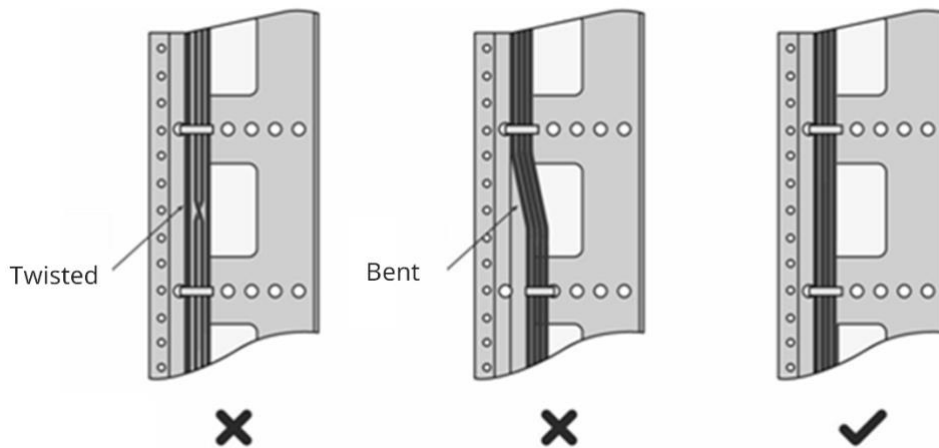
Figure 7-3 Bundling Cables (1)

- Cables of different types (such as power cords, signal cables, and grounding wires) should be separated in cabling and bundling. Mixed bundling is not allowed. When they are close to each other, you are advised to adopt crossover cabling. In the case of parallel cabling, maintain a minimum distance of 30 mm (1.18 in.) between power cords and signal cables.
- The cable management brackets and cabling troughs inside and outside the rack should be smooth without sharp corners.
- The metal holes traversed by cables should have a smooth and fully rounded surface or an insulated lining.
- Use cable ties to bundle cables properly. Please do not connect two or more cable ties to bundle cables.
- After bundling up cables with cable ties, cut off the remaining part. The cut should be smooth and trim without sharp corners, as shown in [Figure 7-4](#).

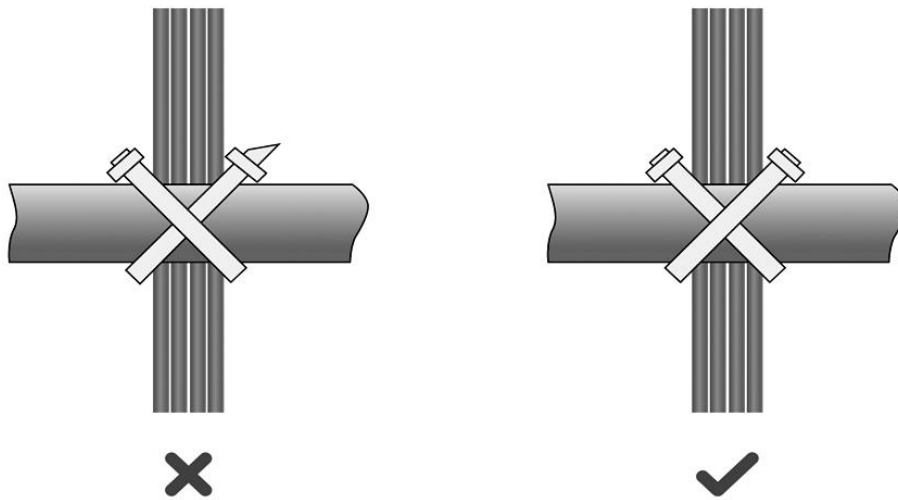
Figure 7-4 Bundling Cables (2)

- When cables need to be bent, bundle them first but do not tie cables within the bend. Otherwise, stress may be generated on the cables and cause the wires inside to break, as shown in [Figure 7-5](#).

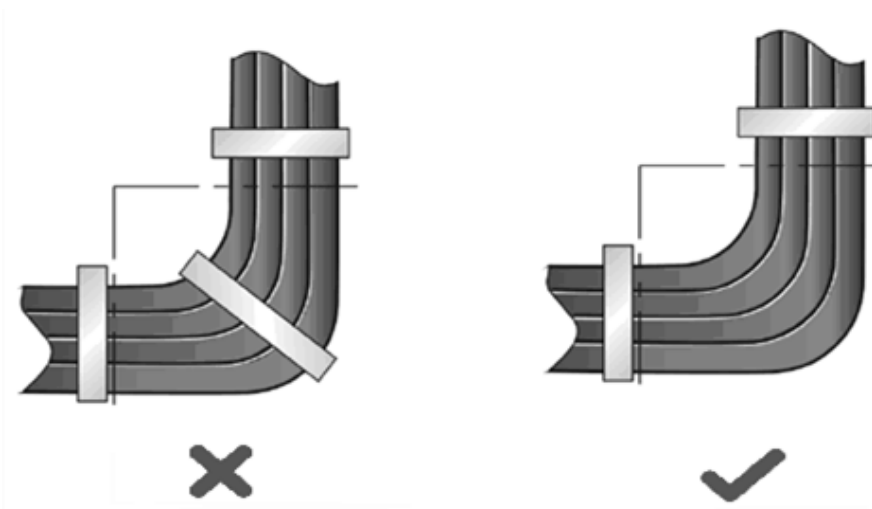
Figure 7-5 Bundling Cables (3)

- Cables not to be assembled or the remaining parts of cables should be folded and placed in a proper position of the rack or cable management trough. The proper position refers to a position that does not affect the equipment running or damage the equipment or cables.
- Power cords must not be bundled on the guide rails of moving parts.
- The power cords connecting moving parts such as door grounding wires should be

reserved with some excess after being assembled to avoid suffering tension or stress. When a moving part reaches the installation position, the remaining cable part should not touch heat sources, sharp corners, or sharp edges. If heat sources must be touched, high-temperature cables should be used.

- When using screw threads to secure a cable lug, ensure that the bolt or screw is properly tightened and take measures to prevent it from loosening, as shown in [Figure 7-6](#).

Figure 7-6 Fastening Cables

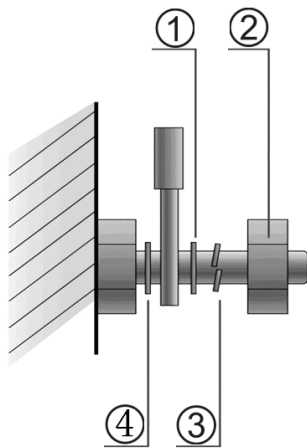

Table 7-2 Fastening Cables

No.	Component
1	Flat washer
2	Nut
3	Spring washer
4	Flat washer

- Hard power cords should be secured near the cable termination area to prevent stress on the cable termination area and cables.
- Do not use tapping screws to secure cable lugs.
- Power cords of the same type and in the same cabling direction should be bundled

up into cable bunches, with cables in cable bunches clean and straight.

- Bundle cables by using cable ties according to the following table.

Cable Bunch Diameter	Bundling Spacing
10 mm (0.39 in.)	80 mm to 150 mm (3.15 in. to 5.91 in.)
10 mm to 30 mm (0.39 in. to 1.18 in.)	150 mm to 200 mm (5.91 in. to 7.87 in.)
30 mm (1.18 in.)	200 mm to 300 mm (7.87 in. to 11.81 in.)

- Do not tie cables or bundles in a knot.
- For wiring terminal blocks (such as circuit breakers) with cord end terminals, the metal part of the cord end terminal should not be exposed outside the terminal block when assembled.